

ASSEMBLED DIMENSIONS: 24" DEEP X 60" WIDE X 35" TALL



ASSEMBLY INSTRUCTION, WB-200-24

PROPRIETARY AND CONFIDENTIAL

THE INFORMATION CONTAINED IN THIS DRAWING IS THE SOLE PROPERTY OF QSP. ANY REPRODUCTION IN PART OR AS A WHOLE WITHOUT THE WRITTEN PERMISSION OF QSP IS PROHIBITED.

ITEM NO.	PART NUMBER	DESCRIPTION	QTY.
1	WB-200-018	DOOR PULL	2
2	WB-200-017	3/8-16 X 1-1/2 ELEVATOR BOLT	4
3	WB-B2460	BASE WM FOR 24 X 60 CABINET	1
4	WB-BK60	BACK PANEL, 60" W CABINET	1
5	WB-S24	SIDE PANEL WM FOR 24" D CABINET	2
6	WB-SH24	SHELF WM FOR 24 X 60 CABINET	1
7	WB-T2460	TOP WM, 24 X 60 CABINET	1
8	WB-TS60	UPPER TRACK SUPPORT, 60" W CABINET	1
9	WB-D20024-WM	WELDMENT, 2 DOOR, WORK BENCH	2
10	CWS-FB001	FLANGE BEARING, PLASTIC DOOR BEARING	4
11	CWS-MC001	MAGNETIC DOOR CATCH	2



ASSEMBLY INSTRUCTION, WB-200-24

PROPRIETARY AND CONFIDENTIAL

THE INFORMATION CONTAINED IN THIS DRAWING IS THE SOLE PROPERTY OF QSP. ANY REPRODUCTION IN PART OR AS A WHOLE WITHOUT THE WRITTEN PERMISSION OF QSP IS PROHIBITED.

STEP

1

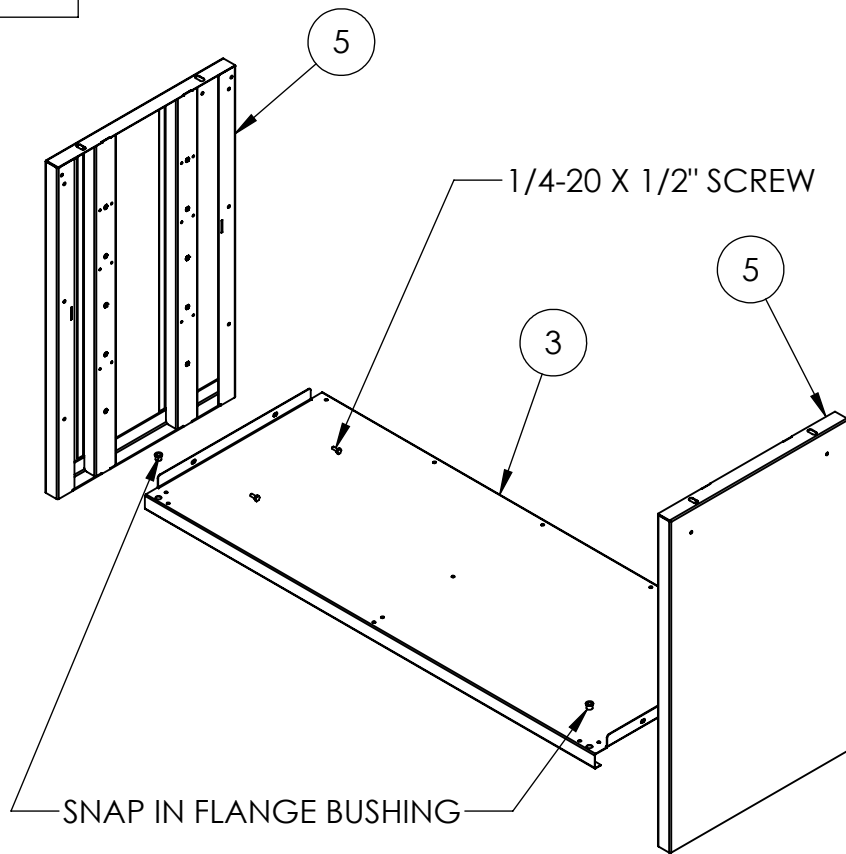

STEP

2

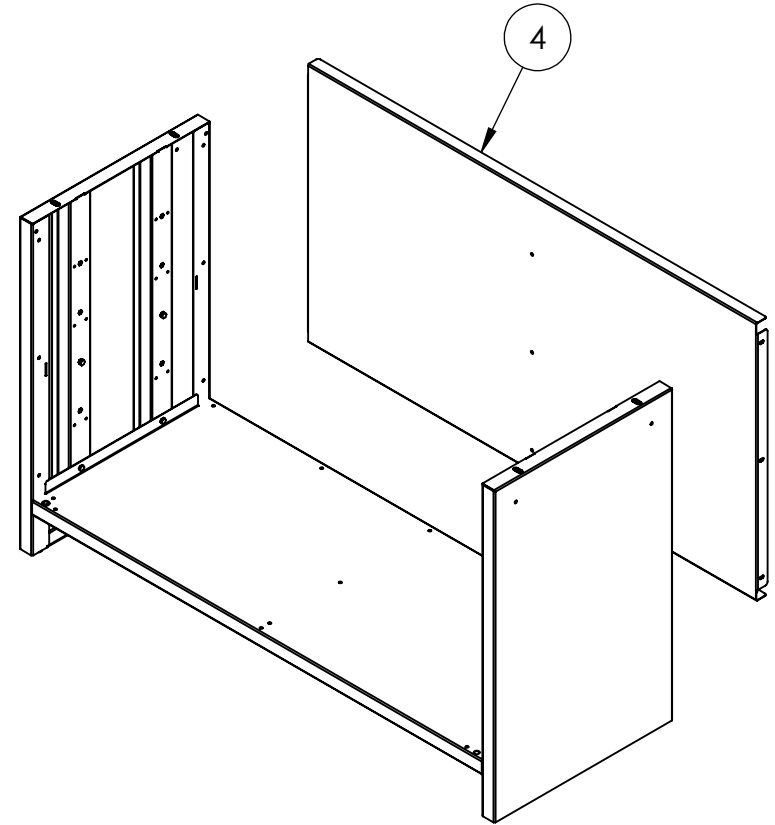

USING (4) 1/4-20 X 1/2" SCREWS, WITH THE LEFT & RIGHT PANELS STANDING UPRIGHT, INSTALL THE CABINET BASE. INSTALL (2) FLANGE BEARINGS INTO BASE FOR DOORS.

INSTALL BACK PANEL USING 1/4-20 X 1/2" SCREWS AND NYLOCK NUTS (11).



ASSEMBLY INSTRUCTION, WB-200-24

PROPRIETARY AND CONFIDENTIAL

THE INFORMATION CONTAINED IN THIS DRAWING IS THE SOLE PROPERTY OF QSP. ANY REPRODUCTION IN PART OR AS A WHOLE WITHOUT THE WRITTEN PERMISSION OF QSP IS PROHIBITED.

STEP

3

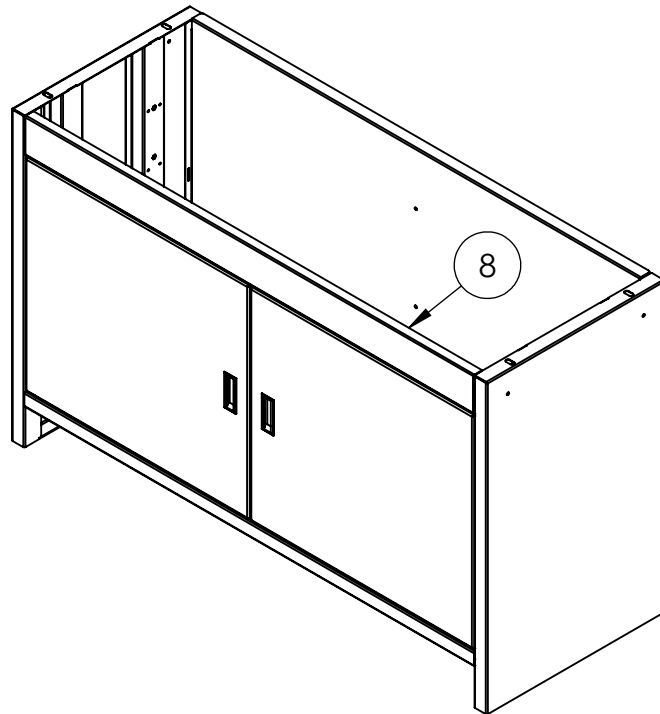

INSTALL DOOR HARDWARE INTO BOTH DOORS. PLACE DOORS THROUGH BOTTOM BUSHINGS, THEN LOWER UPPER PANEL INTO PLACE AND SECURE WITH SCREWS & NUTS

STEP

4

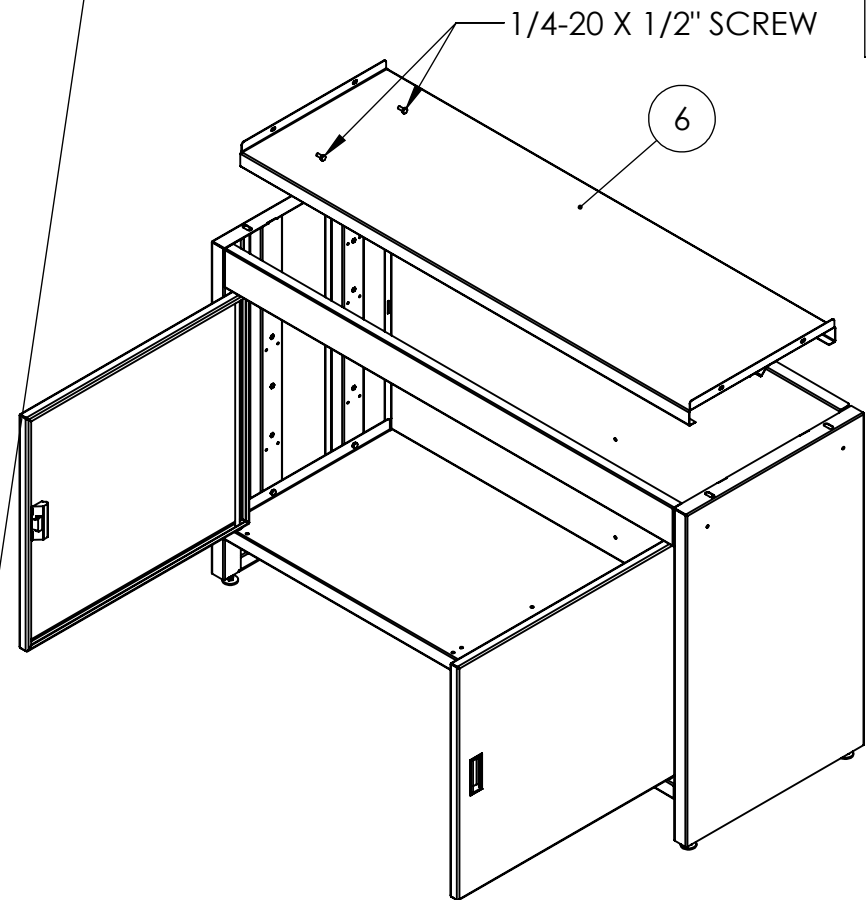

WHILE THE TOP IS REMOVED, INSTALL MIDDLE SHELF AT HEIGHT REQUIRED (3 POSITIONS ARE POSSIBLE) USING (4) 1/4-20 X 1/2" SCREWS.



ASSEMBLY INSTRUCTION, WB-200-24

PROPRIETARY AND CONFIDENTIAL

THE INFORMATION CONTAINED IN THIS DRAWING IS THE SOLE PROPERTY OF QSP. ANY REPRODUCTION IN PART OR AS A WHOLE WITHOUT THE WRITTEN PERMISSION OF QSP IS PROHIBITED.

STEP

5

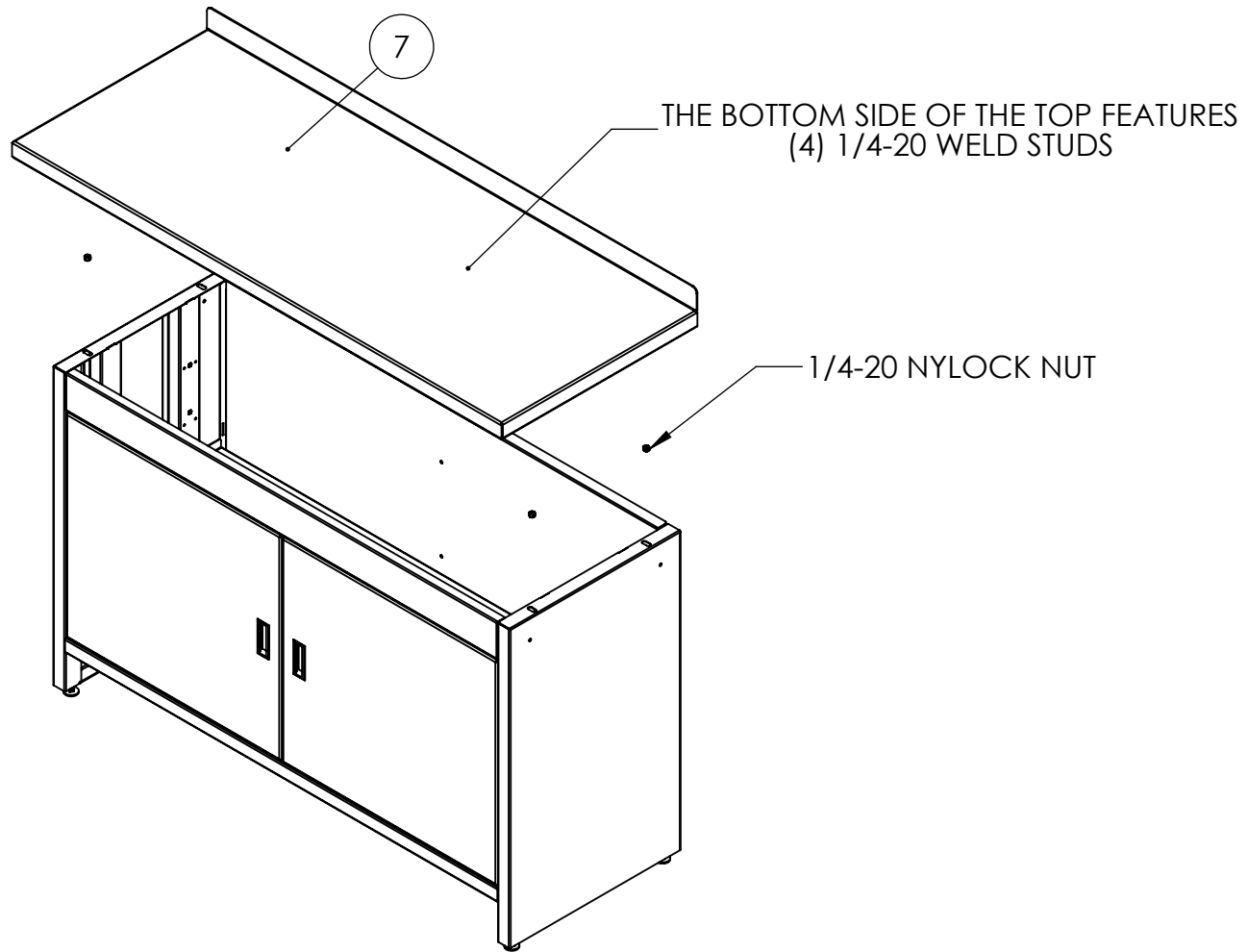

INSTALL WORK TOP USING (4) NYLOCK NUTS FROM INSIDE CABINET.
ENSURE ALL FASTENERS ARE TIGHTENED AND EVERYTHING IS SQUARE.



ASSEMBLY INSTRUCTION, WB-200-24

PROPRIETARY AND CONFIDENTIAL

THE INFORMATION CONTAINED IN THIS DRAWING IS THE SOLE PROPERTY OF QSP. ANY REPRODUCTION IN PART OR AS A WHOLE WITHOUT THE WRITTEN PERMISSION OF QSP IS PROHIBITED.